

INTERNATIONAL APPLICATION PUBLISHED UNDER THE PATENT COOPERATION TREATY (PCT)

(51) International Patent Classification ⁵ : E21D 20/00, 21/00	A1	(11) International Publication Number: WO 92/01859 (43) International Publication Date: 6 February 1992 (06.02.92)
<p>(21) International Application Number: PCT/AU91/00315</p> <p>(22) International Filing Date: 16 July 1991 (16.07.91)</p> <p>(30) Priority data: PK 1221 17 July 1990 (17.07.90) AU</p> <p>(71) Applicant (for all designated States except US): COMMONWEALTH SCIENTIFIC AND INDUSTRIAL RESEARCH ORGANISATION [AU/AU]; Limestone Avenue, Campbell, ACT 2601 (AU).</p> <p>(72) Inventor; and (75) Inventor/Applicant (for US only): WINDSOR, Christopher, Reginald [GB/AU]; 70 Eric Street, Cottesloe, W.A. 6011 (AU).</p> <p>(74) Agents: PERNAT, Alfred et al.; Sirotech Limited, 580 Church Street, Richmond, VIC 3121 (AU).</p>	<p>(81) Designated States: AT (European patent), AU, BE (European patent), CA, CH (European patent), DE (European patent), DK (European patent), ES (European patent), FR (European patent), GB (European patent), GR (European patent), IT (European patent), LU (European patent), NL (European patent), SE, SE (European patent), US.</p> <p>Published With international search report.</p>	
(54) Title: ROCK BOLT SYSTEM AND METHOD OF ROCK BOLTING		
(57) Abstract		
<p>A rock bolt system comprises an inner part (1) disposed within an outer part (10). The inner part comprises an elongated tube having an axial depression (2) and an internal pressure fluid receiving chamber (4) which is closed at both of its ends. A fluid inlet communicates with the fluid receiving chamber. The outer part (10) comprises an elongated tube having a longitudinal slot (12), which slot extends at least part way along the length of the outer part tube. In use, the rock bolt system is placed in an oversized borehole (20) and pressurised fluid applied to the fluid receiving chamber. This causes the device to expand laterally and engage the walls of the borehole.</p>		

FOR THE PURPOSES OF INFORMATION ONLY

Codes used to identify States party to the PCT on the front pages of pamphlets publishing international applications under the PCT.

AT	Austria	ES	Spain	MG	Madagascar
AU	Australia	FI	Finland	ML	Mali
BB	Barbados	FR	France	MN	Mongolia
BE	Belgium	GA	Gabon	MR	Mauritania
BF	Burkina Faso	GB	United Kingdom	MW	Malawi
BG	Bulgaria	GN	Guinea	NL	Netherlands
BJ	Benin	GR	Greece	NO	Norway
BR	Brazil	HU	Hungary	PL	Poland
CA	Canada	IT	Italy	RO	Romania
CF	Central African Republic	JP	Japan	SD	Sudan
CC	Congo	KP	Democratic People's Republic of Korea	SE	Sweden
CH	Switzerland	KR	Republic of Korea	SN	Senegal
CI	Côte d'Ivoire	LI	Liechtenstein	SU ⁺	Soviet Union
CM	Cameroon	LK	Sri Lanka	TD	Chad
CS	Czechoslovakia	LU	Luxembourg	TC	Togo
DE	Germany	MC	Monaco	US	United States of America
DK	Denmark				

⁺ It is not yet known for which States of the former Soviet Union any designation of the Soviet Union has effect.

ROCK BOLT SYSTEM AND METHOD OF ROCK BOLTING

This invention relates to a rock bolting system. The invention is also concerned with a method of rock bolting.

There is a large number of rock bolt devices commercially available for installation within boreholes drilled into rock. These have a variety of general and special uses as rock reinforcement in both civil and mining engineering. One particular class of these devices is known as "Friction Rock Stabilisers". These devices are usually compressed or expanded to fit the borehole and consequently achieve their reinforcing ability by virtue of friction (and to some extent mechanical interlock) at the interface between their outer surface and the borehole wall. These devices include the "Swellex", the "Split Set", the "Pipe Bolt" and the "Rock Nail".

"Swellex" bolts were introduced into Australia in approximately 1984. The bolt is described in Australian Patent Application no. 545968 and essentially comprises an elongated tube which has an axial depression and an internal pressure fluid receiving chamber which is closed at both ends but has a fluid inlet at one end thereof. The bolt may also comprise a fixed sleeve on one end of the tube which is the outer end of the tube, the sleeve and tube having a hole there through to communicate with the internal chamber of the tube so that the hole forms the fluid inlet. When the device is installed in an oversize bore hole and fluid is injected through the inlet the inflation pressure causes both the steel tube and to a lesser extent, the rock to expand. When the pressure is released, the rock relaxes and an interface pressure is established between the steel tube

and the rock surface. Resistance to pull-out is caused by friction and mechanical interlock between the steel tube and the rough borehole wall.

A consistent and quality assured installation is the primary requirement for all rock reinforcement systems. This prerequisite is assured for the "Swellex" bolt by an elegant insertion and inflation procedure. Furthermore, this simple procedure does not require high operator expertise. However, the mechanical properties of the installed "Swellex" can be improved to address the fundamental modes of action required of rock reinforcing systems. That is, modification to the axial and shear strengths and stiffnesses.

Another form of stabilising device is the "Split Set" bolt. The "Split Set" bolt has been used in Australia since the 1970's. The Split Set bolt comprises a split tube formed from a hot-rolled steel sheet of a certain thickness which is formed in a tube rolling mill. Instead of closing the tube a longitudinal slot is left open. The split tube is cut to length, one end is tapered and a formed ring is welded to the opposite end. The tapered end allows forced insertion into an undersized borehole. The ring is intended to support a face plate at the borehole collar. In use, the "Split Set" bolt is driven into the bore hole, compressing the split tube and causing an interfacial pressure between the bolt and the rock. Resistance to pull out is due mainly to friction.

The ideal rock reinforcement device is one in which the design capacity is achieved at an appropriate stiffness without rupture of the element, irrespective of displacement. To achieve this, slip must occur between one or more of the constituent interfaces between the device and the host rock. That is, an ideal bolt may be

loaded to a design load prior to slip and that a substantial proportion of this load is maintained during subsequent slippage.

The "Split Set" bolt described above goes some way towards this ideal. Slippage can occur for large displacements without rupture occurring. However, its frictional anchoring capacity is usually significantly less than its axial strength. To increase anchoring capacity a smaller bore hole may be used. However, this makes installation difficult if not impossible.

The "Swellex" bolt has the potential to achieve the stated aims of an ideal device. This could be achieved by reducing the installation pressure. However, reduction of installation pressure results in unpredictable performance. Thus, the great advantage of a consistent high quality installation is lost.

DISCLOSURE OF THE INVENTION

The prime objective of the present invention is to provide a rock bolt system and a method for installing rock bolts which overcome, or at least mitigate, some of the problems with the previously described rock bolts.

Accordingly, in one aspect, there is provided a rock bolt system comprising an inner part disposed within an outer part, said inner part comprising a fluid expansible elongated tube having an internal closed ended fluid receiving chamber having a fluid inlet, said outer part comprising an elongated tube having a longitudinal slot, said slot extending at least part way along the length of said tube of said outer part.

In a second aspect, the present invention provides a rock bolt system comprising an inner part disposed

within outer part, said inner part comprising an elongated tube having an axial depression and an internal pressure fluid receiving chamber which is closed at both of its ends and having a fluid inlet communicating with said fluid receiving chamber, said outer part comprising an elongated tube having a longitudinal slot, said slot extending at least part way along the length of said tube of said outer part.

In a further aspect, the present invention provides a method for rock bolting said method comprising providing a rock bolt system within a borehole, said rock bolt system comprising an inner part disposed within an outer part, said inner part comprising a fluid expansible elongated tube having an internal closed ended fluid receiving chamber having a fluid inlet, said outer part comprising an elongated tube having a longitudinal slot, said slot extending at least part way along the length of said tube of said outer part, supplying fluid under pressure to said fluid receiving chamber through said fluid inlet to expand said expansible tube and expand said slotted tube in said borehole.

The inner part may be an Atlas Copco standard "Swellex" bolt.

Preferably, although not necessarily, after expansion the aperture in the outer tube is diametrically opposite to the depression in the inner tube.

This invention relates to a new and additional device which, at first glance would appear to comprise simply coupling the "Swellex" with the "Split Set". Although these two devices are particularly relevant to this invention the fundamental mechanics of installation and operation of the present invention are markedly

different from that of either individual or coupled use of the "Swellex" and the "Split Set".

The rock bolt system of the present invention has four principal attributes. Two are concerned with its installation into boreholes and two are concerned with its operation as a reinforcement system. In terms of installation the invention maintains the advantages of the original "Swellex":

- ease of insertion in the borehole, combined with
- quality assured installation.

In terms of operation it provides:

- flexibility of design configuration, together with
- optimum use of material properties as reinforcement.

The aim of the present invention is to provide a reinforcement assembly which may be arranged to supply the required axial and shear capacities and stiffnesses to suit different modes of operation demanded of reinforcement systems. For example this may be achieved by varying :

- the outer tube geometry (i.e. profile, length, diameter, thickness, slot length)
- the outer tube properties (i.e. material type, constitutive behaviour, coefficient of friction)
- the inflation agent and procedure (pressure, fluid type and method)
- the interface between the inner and outer components (lubricated or rough interface may be arranged).

Similarly the longevity and corrosivity and suitability to different environments may be arranged by judicious choice of insertion fluid agents and constituent component material types and coatings.

The invention is preferably used in the same nominal sizes as the "Swellex" and the "Split Set" bolts and is also compatible with current drilling and installation machinery. This is currently limited to devices to suit approximately 38mm to 40mm and approximately 44mm to 46mm diameter boreholes and in lengths ranging from approximately 1m to 4m. Clearly, the rock bolt system of the invention is not limited by size and is equally applicable in larger or smaller diameters and lengths.

In order that the invention may be more fully understood we provide the following non-limiting examples.

Brief Description of the Drawings

Figure 1 shows a cross-sectional view of a rock bolt system in accordance to the invention prior to expansion;

Figure 2 shows a cross-sectional view of a rock bolt system in accordance with the invention after expansion;

Figure 3 is a graph showing axial test results; and

Figure 4 is a graph showing shear test results.

The most basic form of the invention is shown in Figure 1. The rock bolt system comprises an inner tube 1 (which may be a "Swellex" bolt P.A. No. 545968).

The invention will now be described in reference to the use of a "Swellex" bolt as the inner tube 1, however the

invention is not to be seen as limited to the use of this bolt.

The "Swellex" bolt 1 is located within a second outer tube 10 which has a longitudinal slot 12. It will be seen from the drawing that the axial depression 2 of the "Swellex" bolt is located diametrically opposite the aperture 12 of the outer tube. The first tube ("Swellex" bolt) - second tube combination is located within borehole 20 of rock 25. The outer tube may be tapered at one end to facilitate insertion into the borehole. Expansion is achieved by supplying high pressure liquid to the inner "Swellex" bolt. In the process of expansion the inner "Swellex" bolt eventually comes into contact with the outer split tube effecting expansion of the outer split tube against the walls of the borehole.

Figure 2 shows the bolting system of the invention after expansion of the inner "Swellex" bolt 30.

Whilst the outer tube adds to the apparent stiffness of the bolt, it should be noted that the axial stiffness is also affected by the rate of load transfer from the rock to the outer tube and from this tube to the inner "Swellex" bolt.

A laboratory testing program has been undertaken to quantify some of the differences in response between the standard "Swellex" bolt and two variants of the bolt according to the invention.

Reinforcing devices are designed to reinforce discontinuities such as pre-existing joints or propagating cracks. They attempt to control the opening and shearing displacements that can occur at these discontinuities. The laboratory tests were designed to

simulate these two aspects of reinforcement loading, discontinuity opening or tensile loading and discontinuity shearing or shear loading.

The standard "Swellex" bolt manufactured to suit 38mm to 40mm diameter boreholes was chosen for testing. Preferred bolt variants according to the invention comprise an inner standard "Swellex" bolt with an outer split tube sleeve. In the first variant of the invention, the outer sleeve comprised a 31.8mm diameter, 1.6mm wall thickness steel tube. In the second variant, the outer sleeve comprised a 35.0mm diameter, 3.2mm wall thickness steel tube.

Testing Arrangements

In all cases the specimens were installed within 40mm internal diameter, 17.5mm thick walled steel containment tubes. These very thick and rigid containment tubes were designed to duplicate the radial confinement supplied by an average rock. The containment tubes are made up of two tube lengths butted together. The reinforcement device is inserted into the tube to span this butt joint and then inflated. Once inflated the butt joint is used to simulate a discontinuity by forcing the specimen to extend or shear at this interface. This arrangement of the specimen containment tubes was compatible with both the axial and the shear testing facilities.

Discontinuity opening or tensile loading was simulated by securing the two containment tubes and pulling them apart, thereby inducing tension in the reinforcing device at the test interface. The containment tubes were secured by a universal testing machine approximately 500mm either side of the test interface. The variables

measured included the load supplied by the machine and the axial displacement at the test interface.

Discontinuity shearing or shear loading was simulated by placing the test specimen in a shear facility. The facility is placed within a universal test machine which supplies a shearing force at the test interface. The transverse movement of one containment tube relative to the other side of the test interface causes shearing of the specimens. The variables measured included the shear load supplied by the machine and the shear displacement at the test interface.

Results and Comparison

A set of axial tension test was performed to determine whether the behaviour of standard "Swellex" bolts installed in thick walled steel containment tubes was representative of their behaviour in rock. The embedment length on one side of the test interface was held constant at relatively long length (1.5m) and the embedment length on the other side of the test interface was varied. This arrangement allowed slippage from the short embedment length to be studied. The results summarised in Table 1 are in agreement with the performance expected of standard "Swellex" bolts installed in hard rock. The strength increases as the embedment length increases and failure is by slippage of the "Swellex" bolts installed in hard rock. The strength increases as the embedment length increases and failure is by slippage of the "Swellex" from within the containment tube. Although failure at the longer embedment lengths was by slippage, the yield strength of the "Swellex" bolt material was exceeded.

TABLE 1. Summary of Laboratory Tension Tests

Long Embedment (m)	Short Embedment (m)	Peak Load (kN)
1.5	0.50	80
1.5	0.75	100
1.5	1.00	110
1.5	1.25	120

A series of tests was designed to compare the performance of rock bolts according to the invention with the standard "Swellex" in both axial tension and shear. The results for axial tension tests are summarised in Figure 3 and the results obtained in the shear tests are summarised in Figure 4.

These results demonstrate that:

- axial load transfer decreases as the split tube thickness increases
- shear strength increases as the outer split tube thickness increases.

These results show that the bolt of the invention can be arranged to achieve a range of axial load transfer and shear strengths. This ability is consistent with the requirements of a variety of reinforcement applications for excavations in jointed rock. This range of mechanical properties can be achieved whilst maintaining a consistent and quality assured reinforcement installation.

In practice, reinforcement devices are subject to combined axial and shear loading caused by opening and shear of the discontinuities which they reinforce. It is therefore particularly important that bolts of the

- 11 -

invention have a high shear strength combined with adequate resistance to axial loading.

The preliminary tests have used a standard "Swellex" bolt for inflation and outer split tubes made from steel. This has dictated the range of sizes used for the bolts. It will be appreciated however that the size of the bolt will not be limited to these sizes and the outer tube may be made from a range of materials consistent with the requirements of the application.

THE CLAIMS DEFINING THE INVENTION ARE AS FOLLOWS:

1. A rock bolt system comprising an inner part disposed within an outer part, said inner part comprising a fluid expansible elongated tube having an internal closed ended fluid receiving chamber having a fluid inlet, said outer part comprising an elongated tube having a longitudinal slot, said slot extending at least part way along the length of said tube of said outer part.
2. A rock bolt system comprising an inner part disposed within an outer part, said inner part comprising an elongated tube having an axial depression and an internal pressure fluid receiving chamber which is closed at both of its ends and having a fluid inlet communicating with said fluid receiving chamber, said outer part comprising an elongated tube having a longitudinal slot, said slot extending at least part way along the length of said tube of said outer part.
3. A rock bolt system as claimed in claim 2 wherein said inner and outer parts are oriented such that said axial depression is located substantially diametrically opposite said longitudinal slot.
4. A method for rock bolting comprising providing a rock bolt system within a borehole, said rock bolt system comprising an inner part disposed within an outer part, said inner part comprising a fluid expansible elongated tube having an internal closed ended fluid receiving chamber having a fluid inlet, said outer part comprising an elongated tube having a longitudinal slot, said slot extending at least part way along the length

of said tube of said outer part, supplying fluid under pressure to said fluid receiving chamber through said fluid inlet to expand said expansible tube in said borehole and thereby expand said slotted tube in said borehole.

5. A method for rock bolting as claimed in claim 4 wherein said inner part comprises an elongated tube having an axial depression and an internal pressure fluid receiving chamber which is closed at both of its ends and having a fluid inlet communicating with said chamber.
6. A method for rock bolting according to claim 5 wherein said axial depression develops outwardly when fluid under pressure is supplied to said fluid receiving chamber to thereby laterally expand said expansible tube.
7. A method for rock bolting according to claim 5 or claim 6 wherein said fluid is pressurised water.
8. A method for rock bolting according to claim 5 or claim 6 where said inner and outer parts are oriented such that said axial depression is located substantially diametrically opposite said longitudinal slot.

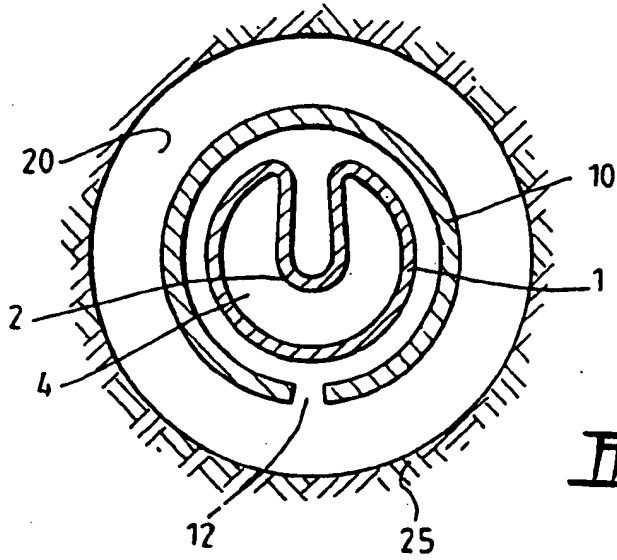

FIG. 1.

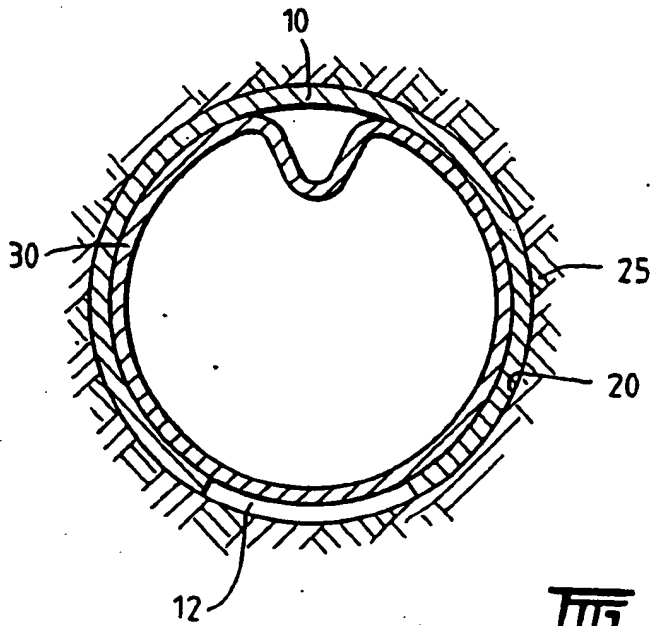
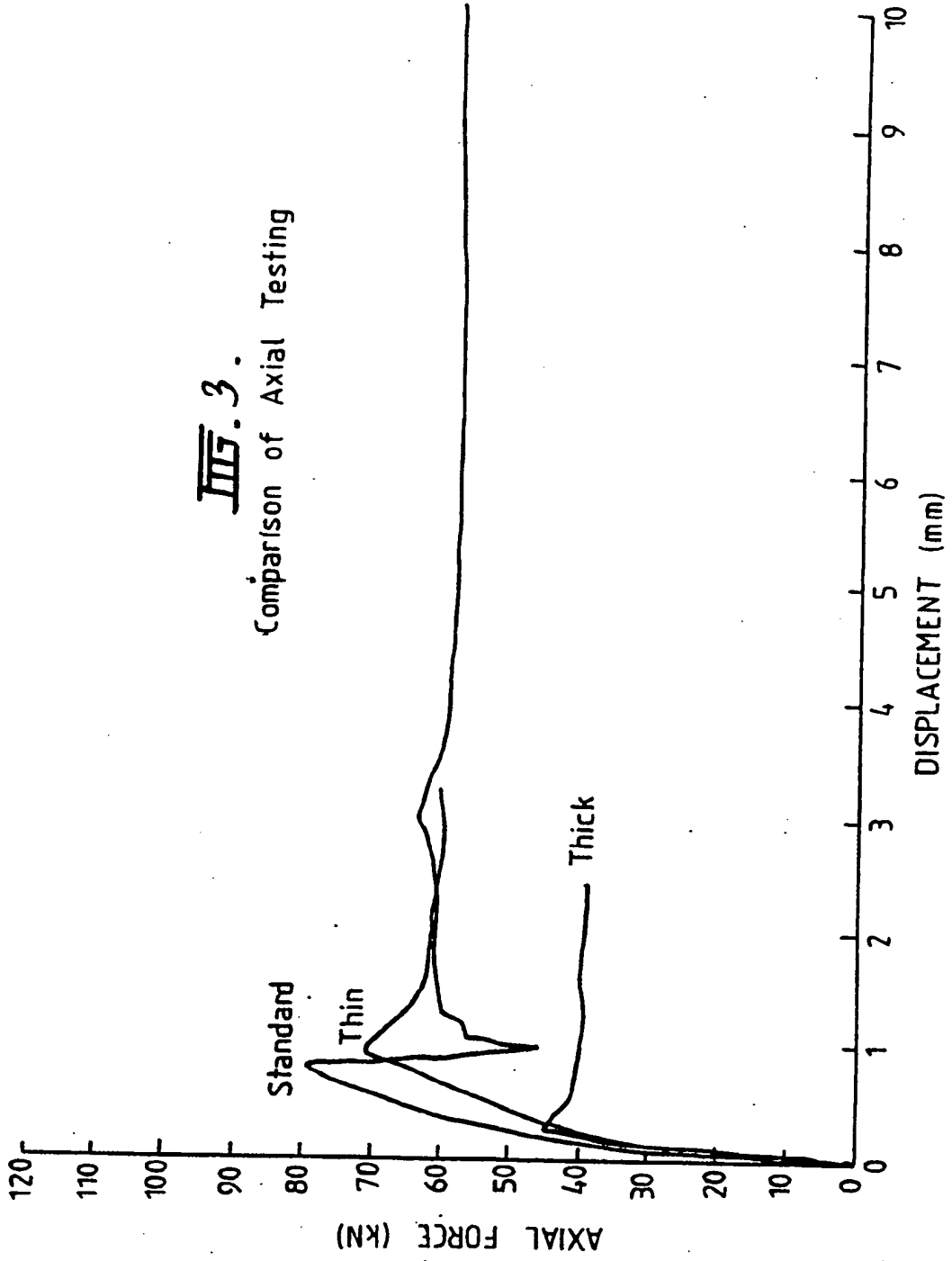

FIG. 2.

III.3.
Comparison of Axial Testing



III. A.

Comparison of Shear Testing

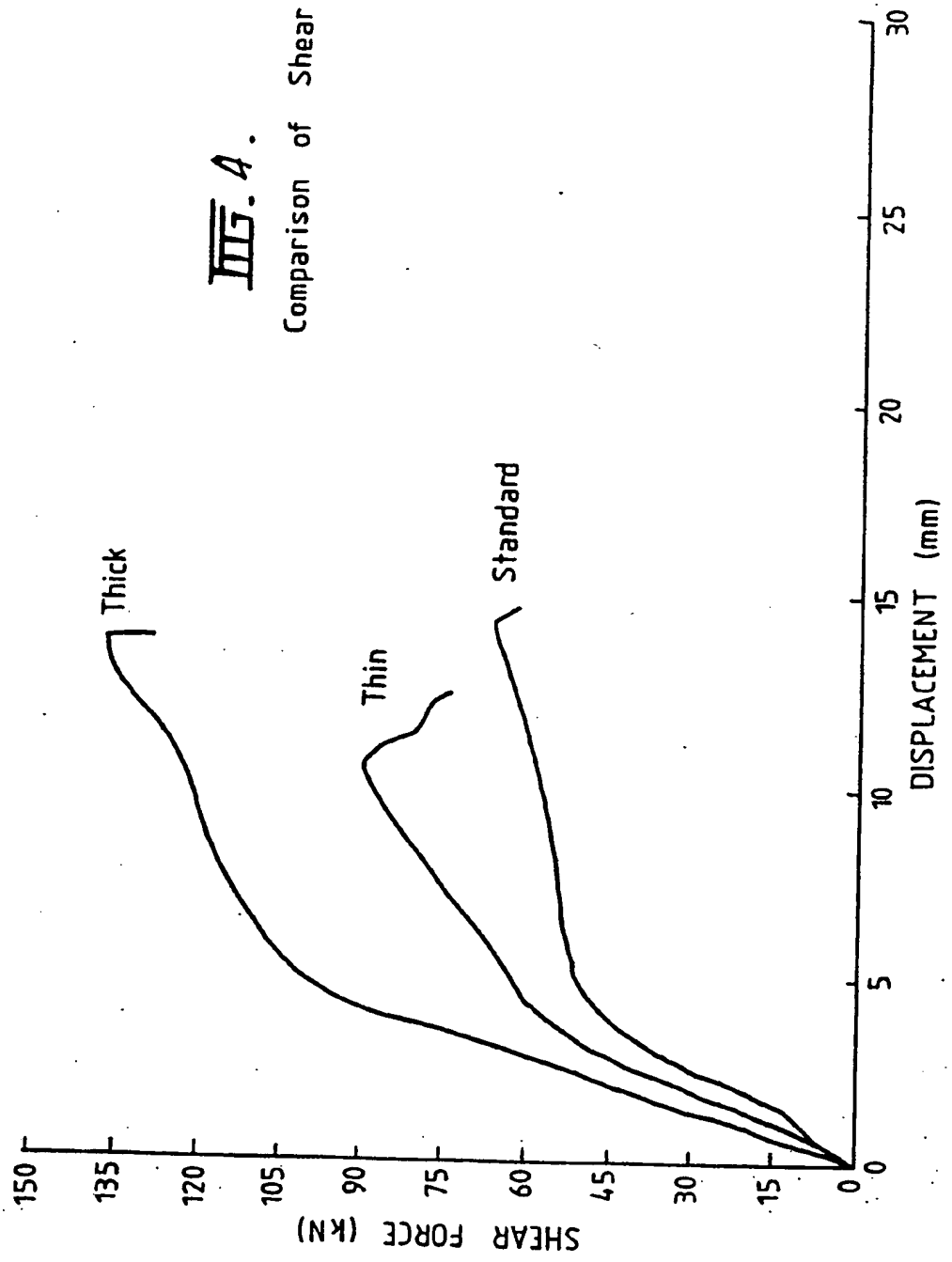

**ANNEX TO THE INTERNATIONAL SEARCH REPORT ON
INTERNATIONAL APPLICATION NO. PCT/AU 91/00315**

This Annex lists the known "A" publication level patent family members relating to the patent documents cited in the above-mentioned international search report. The Australian Patent Office is in no way liable for these particulars which are merely given for the purpose of information.

Patent Document Cited in Search Report		Patent Family Member			
AU 58772/86	AT 48464	CA 1257976	EP 207030		
	FI 862545	JP 62050600	NO 862361		
	SE 8502981	US 4696606	ZA 8604497		
AU 89439/82	BR 8206034	EP 77762	ES 275496		
	FI 823486	JP 58080099	NO 823460		
	SE 8106165	SU 1255065	US 4511289		
	ZA 8207161				
AU 75054/81	AT 10664	BR 8105714	CA 1180909		
	DE 3167630	EP 47727	FI 812763		
	IN 153175	JP 57077798	NO 812997		
	PL 232949	SE 8105344	US 4423986		
	ZA 8106176				